

Installation manual

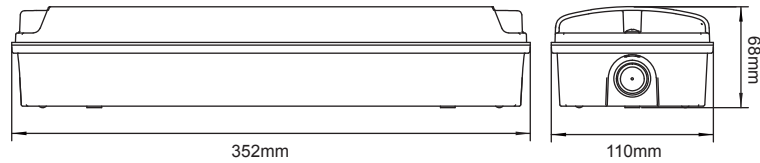

Warning note

Suitable for mounting on normally flammable surface. Green LED indicator indicates battery charging mode. Safety and Performance are in accordance with UL924 Suitable for outdoor use, wall mounted.

If the external flexible cable or cord of this luminaire is damaged, it shall be exclusively replaced by the manufacturer or his service agent or a similar qualified person in order to avoid a hazard. The battery is non-replaceable.

Installation: The installation shall be done by a qualified person.

Model list:

| | |
|----------------------|---------------------------------|
| Model No. | STEML-U9 |
| Rated voltage | AC120-277V~, 50/60Hz |
| Operating mode | Maintained/Non- Maintained |
| Rated wattage | 5W / 1.5W |
| LED | 27PCS SMD*0.2W LED / 5700-6700K |
| Discharge duration | 3h |
| Battery | Ni-Cd SC3,6V 1500mAh |
| Battery life | up to 4 years |
| Power factor | N/A |
| Operating Temp Range | 0°C-40°C |
| IP degree | IP65 |
| Protection class | Class II |
| Dimensions | 352mm×110mm×68mm |
| Weight | 0.65kg |
| Max. mounting height | 8.3ft (2.5m) |

Installation instruction diagram:

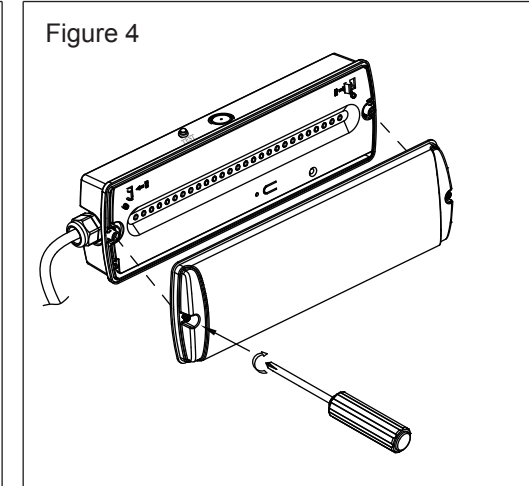
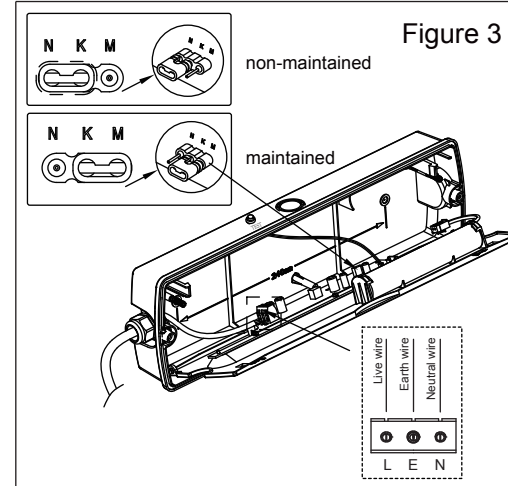
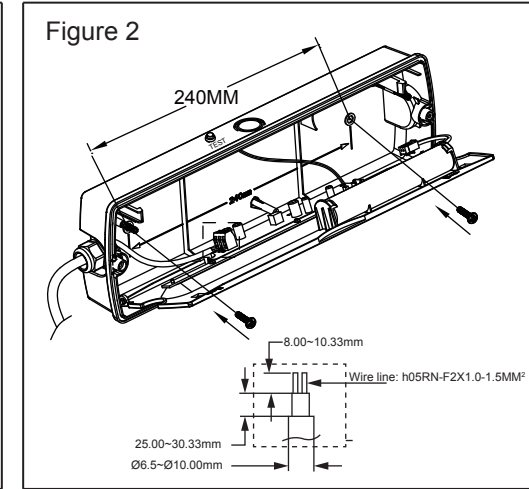
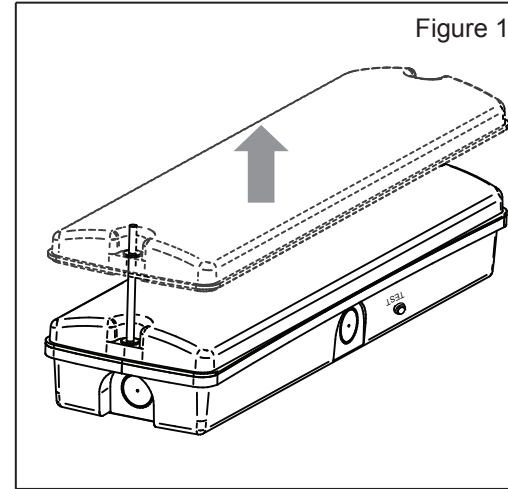

Installation instructions

The light source contained in this luminaire shall only be install by the manufacturer or his service agent or a similar qualified person.

1. Switch off the electricity at the AC power.
2. Remove the diffuser (Figure 1).
3. Body installation (Figure 2).
4. Electrical connection (Figure 3).
5. Attach diffuser (Figure 4).
6. Switch AC power on.

Led replacement

The light source contained in this luminaire shall only be replaced by the manufacturer or his service agent or a similar qualified person.

1. Switch off the electricity at the mains.
2. Remove the diffuser.
3. Remove the screws on the gear tray, and open the fitting
4. Unplug the battery lead from the main board.
5. Unplug the LED lead from the PCB board.
6. Unplug the LED PCB from the gear tray.
7. Change the LED Module based on the module name on module PCB

TESTING:

The emergency lighting must be inspected and tested regularly in accordance with local Codes of practice,

Note: tests should be carried out during day time for safety reasons.

The testing should be done by a qualified person. in an dry environment.

Move the plastic diffuser, press the test button to simulate failure of mains power, the Emergency light should be on and driven by battery.

The minimum recommended test schedule is as follows: Charge the battery for 36 hours after installation to ensure the battery is full and then observe if the light can discharge for 3 hours.

1. Daily check that charge indicator LED is working.
2. Monthly interrupt power for a short period to check LED lights.
3. Semiannually check 1 hour duration.
4. At the end of year and subsequent year. Check 3 hour duration: batteries must be replaced when they can no longer support 3 hour operation.
5. Complete record sheet on installation and retain file.
6. Update file with ongoing test records for inspection by fire officer or other daily authorized person.



This marking indicates that this product should not be disposed with other household wastes throughout the EU. To prevent possible harm to the environment or human health from uncontrolled waste disposal, recycle it responsibly to promote the sustainable reuse of material resources. To return your used device, please use the return and collection systems or contact the retailer where the product was purchased. They can take this product for environmental safe recycling.

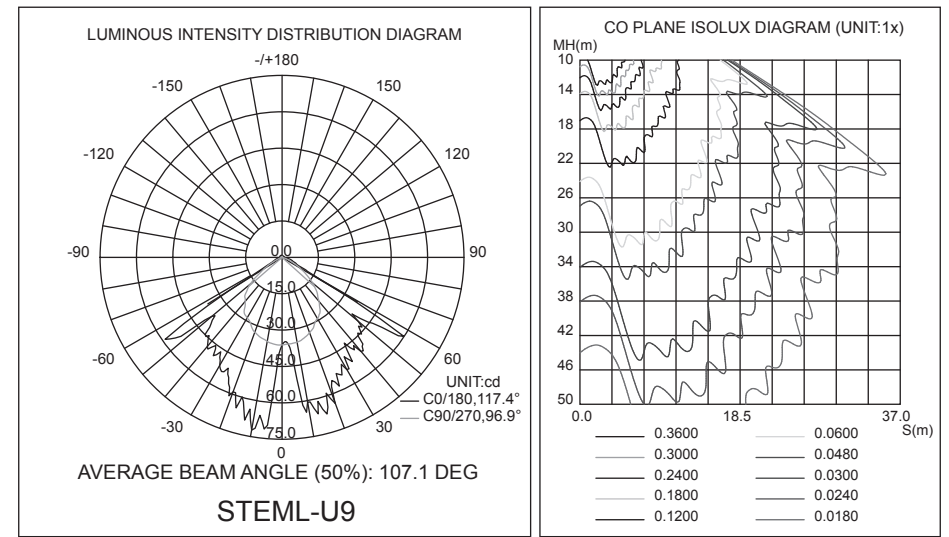

Installation and maintenance Record:

Installer _____

Installation _____

Type _____

Installation test duration & Date _____

| Month | Test | 1 st Year | | 2 st Year | | 3 st Year | | 4 st Year | | 5 st Year | |
|-------|-------|----------------------|------|----------------------|------|----------------------|------|----------------------|------|----------------------|------|
| | | Signed | Date | Signed | Date | Signed | Date | Signed | Date | Signed | Date |
| 1 | Short | | | | | | | | | | |
| 2 | Short | | | | | | | | | | |
| 3 | Short | | | | | | | | | | |
| 4 | Short | | | | | | | | | | |
| 5 | Short | | | | | | | | | | |
| 6 | 1 Hr. | | | | | | | | | | |
| 7 | Short | | | | | | | | | | |
| 8 | Short | | | | | | | | | | |
| 9 | Short | | | | | | | | | | |
| 10 | Short | | | | | | | | | | |
| 11 | Short | | | | | | | | | | |
| 12 | 1 Hr. | | | | | | | | | | |
| | 3Hr. | | | | | | | | | | |