

Model SD-DVH-PT680 DE\EL\HRV\PR

SHIELD

Deluge Pressure Reducing Valves

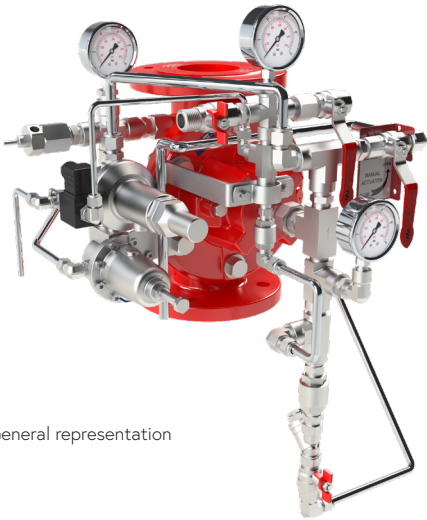

General representation



Fire Protection

Electrically or Hydraulically Actuated, Anti-Columning, Pressure Reducing Deluge Valve

Description

Electrically or hydraulically, pilot controlled deluge/pre-action valve, actuated by the pipeline pressure. The valve is closed in its normal, set position and opens when the hydraulic pressure drops in a water pressurized pilot line, releasing a hydraulic relay, or by an electric command. When tripped, the valve regulates to a steady, preset downstream pressure, regardless of upstream pressure or flow rate fluctuations. An emergency manual release valve is fitted as standard.

Certification & Compliance

UL Listed under VLFT category

ABS Type Approval

Lloyd's Register Approval

ANSI FCI 70-2 Class VI seat leakage class

Fire tested to EN ISO 6182-5:2006 (2"-6" only)



Features & Benefits

- High pressure (PN25/375psi), high flow deluge systems
- Automatic or manual emergency actuation
- Hazardous, flammable & explosion classified area fire suppression
- Superior design featuring exceptionally low pressure losses at high flow rates
- Low lifelong maintenance costs due to straightforward design
- Applicable for water, seawater & foam
- Out of box fully assembled & tested valves
- Factory trimmed for vertical & horizontal installations without modification
- Extensive valve & trim materials selection and corrosion protection coating

Typical Applications

Automatic or Manual Actuated Fire Suppression Systems

Petrochemical, Oil & Gas Installations

Tunnels

Power Generation, Transformer & Transmission Plants



Flammable Storage

Hangers & Airport Terminals

Onshore/Offshore

Mining



Operation

The basic control valve [1] used in this deluge system is a direct-sealing elastomeric diaphragm, hydraulically operated control valve engineered specifically for fire protection systems.

In the standby position, the deluge valve is held closed by the upstream water pressure, trapped in the valve's control chamber. The water pressure enters the control chamber through the priming line ball valve [2], a Y-type strainer [3], a check valve [4] and a T-restrictor [5].

Under fire conditions, the deluge valve opens automatically under any of the following circumstances:

1. A fire alarm control panel (F&G panel) energizes the 3/2-way N.O. solenoid [10] (or de-energizes the coil of a continuously energized ED 100% normally closed solenoid for SIL 3-4 rated systems).
2. The pressure in the wet (hydraulically pressurized) pilot line drops, following bursting of one (or more) of the automatic sprinklers.

When this happens, the pressure in the relay valve [9] drops, causing it to open and allowing the water to begin to drain from the deluge valve's control chamber through the pressure reducing pilot [11]. The deluge valve opens instantly, regulating to a steady, preset downstream pressure, regardless of upstream pressure or flow rate fluctuations. This allows water to flow into the pipeline and through the open sprinklers over the protected area.

Manual emergency actuation is enabled by opening the emergency manual activation valve [6]. When connected through the pressure reducing pilot (upon request), manual actuation causes the deluge valve to regulate the downstream pressure regardless of upstream pressure or flow rate fluctuations. If unspecified, the manual activation valve drains the water to the atmosphere, allowing the deluge valve to open fully. When actuated, the deluge valve opens instantly and allows water to flow into the pipeline and through the open sprinklers over the protected area.

Standby Position

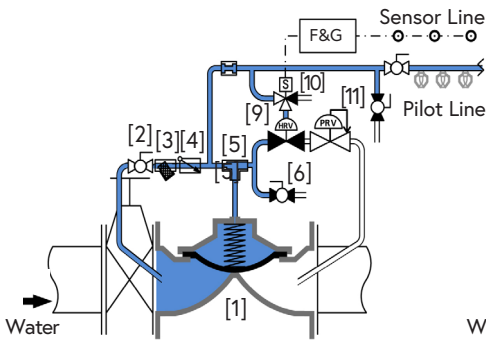

Electrically Actuated & Pressure Reducing

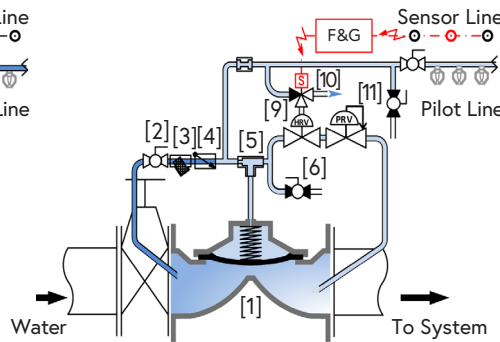

Hydraulically Actuated & Pressure Reducing

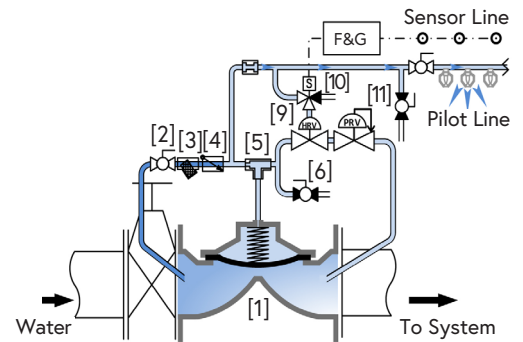

Manually Actuated & Pressure Reducing

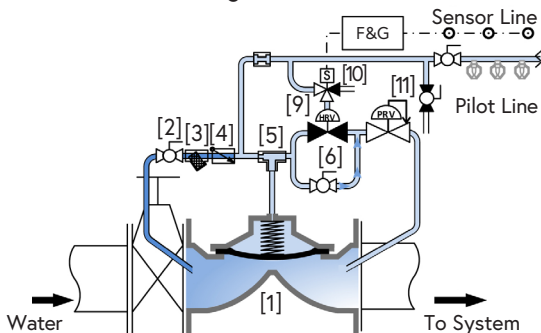

Manually Actuated (Standard)

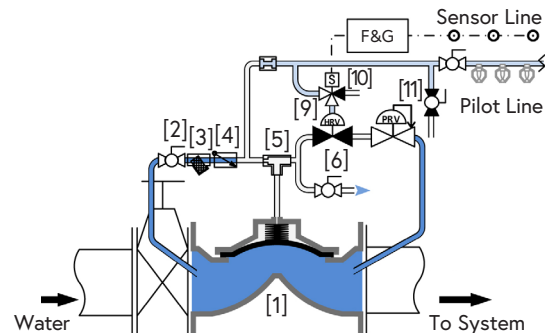

Resetting, maintenance, and periodic testing instructions must be followed as described in detail in the applicable IOM (Installation, Operation & Maintenance) Manual.

Model SD-DVH-PT680 DE\EL\HRV\PR

SHIELD

Deluge Pressure Reducing Valves

Components & Typical Materials

The SD-DVH-PT680 DE\EL\HRV\PR consists of the following components, arranged as shown on the schematic diagram below.

ID	Part	Standard Material	POG (1) Applications
1	Valve Body	See S100 Engineering Data (2)	
2	Ball Valve	Bronze, Stainless Steel Ball	Stainless Steel 316
3	Y-Type Strainer	Bronze, Stainless Steel Screen	Stainless Steel 316
4	Check Valve	Bronze	Stainless Steel 316
5	T-Restrictor	Brass	Stainless Steel 316
6	Manual Emergency Valve	Bronze	Stainless Steel 316
7	Drip Valve	Brass	Stainless Steel 316
8	Pressure Gauge	Stainless Steel	Stainless Steel 316
9	66-2UL Relay	Brass	Stainless Steel 316
10	3/2 Way N.C. Solenoid (3)	Brass	Stainless Steel 316
11	CXPR Pressure Reducing Pilot	Brass, Stainless Steel 316 Seat	Stainless Steel 316

(1) Petrochemical, Oil & Gas

(2) Refer to materials selection guidelines, Engineering Data - Materials: Ductile Iron A-536 65-45-12; Cast Steel A-216 WCB; Cast Steel A-352 LCB; Austenitic Stainless Steel A-351/CF8M; Super Duplex 2507; Nickel-Aluminum-Bronze B-148 UNS C95800

(3) Consult factory

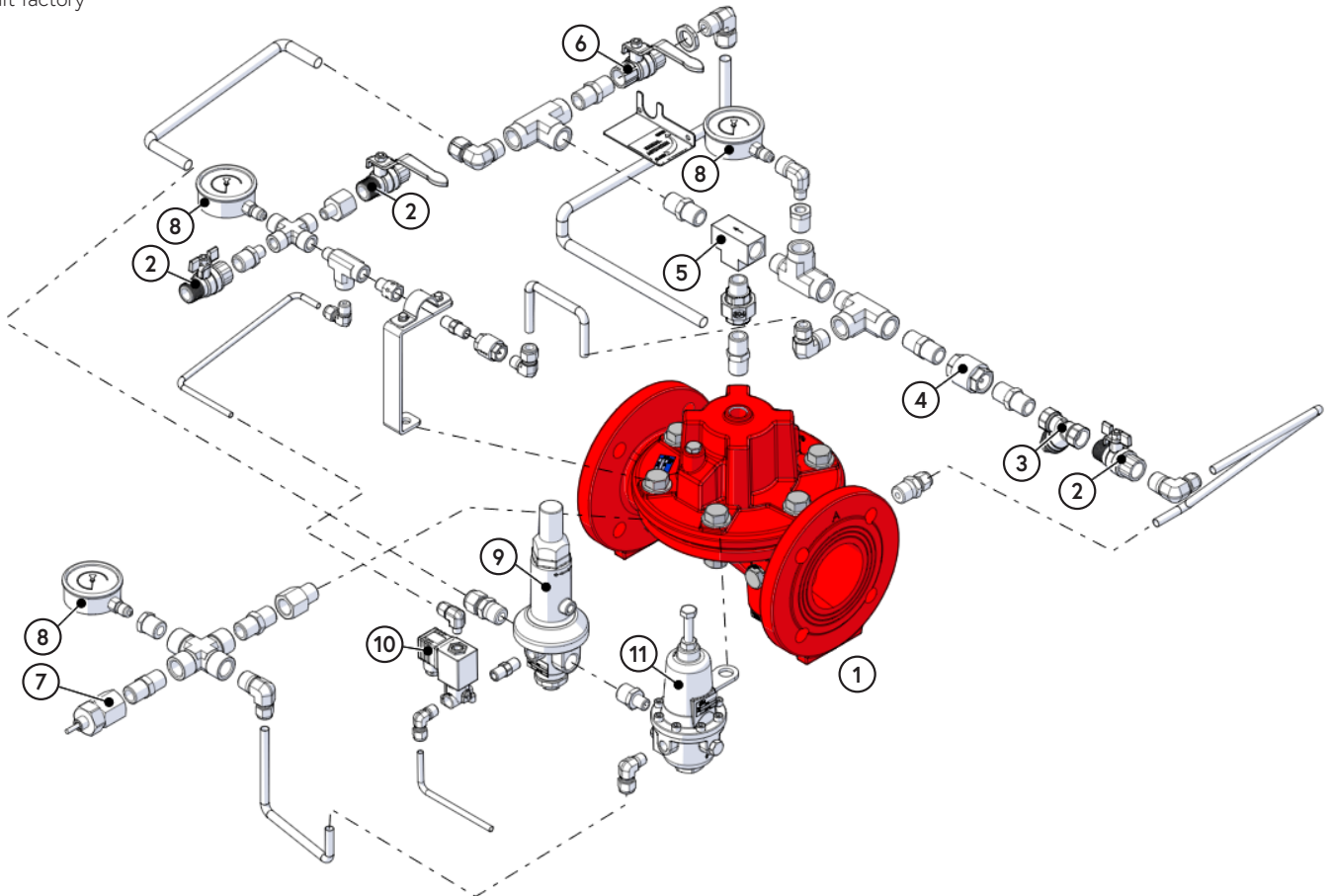

Model SD-DVH-PT680 DE\EL\HRV\PR

Deluge Pressure Reducing Valves



General Arrangement & Dimensions

Standard Sizes							
DIM	2"	2 1/2"	3"	4"	6"	8"	10"
A	9 5/8	9 3/16	12 3/16	14	17 3/16	20 7/8	25
A _G ⁽¹⁾	9 5/8	10	13 3/16	15	17 5/16	21 7/8	--
B	14 13/16	14 13/16	14 13/16	14 13/16	14 13/16	14 13/16	14 13/16
C	9 5/8	9 5/8	9 5/8	9 5/8	9 5/8	10 3/8	12 1/2
D	10 3/8	10 3/8	10 7/8	11 5/16	12 5/8	13 5/16	14 5/16
E	6 11/16	6 11/16	7 3/16	7 5/8	8 7/8	9 5/8	10 5/8
F	3 5/16	3 5/16	4 1/8	4 11/16	5 7/8	7 1/8	8 1/2
G	10 5/8	10 5/8	12 13/16	12 13/16	16 1/8	18 5/8	19 1/2

Approximate Dimensions. ⁽¹⁾ Grooved model length.

Metric Sizes							
DIM	DN50	DN65	DN80	DN100	DN150	DN200	DN250
A	243	233	310	356	436	530	635
A _G ⁽¹⁾	243	253	336	380	440	556	--
B	376	376	376	376	376	376	376
C	244	244	244	244	244	265	318
D	264	264	277	288	320	338	364
E	170	170	183	194	226	244	270
F	85	92 1/2	105	120	150	180	215
G	268	268	324	324	409	472	494

Approximate Dimensions. ⁽¹⁾ Grooved model length.

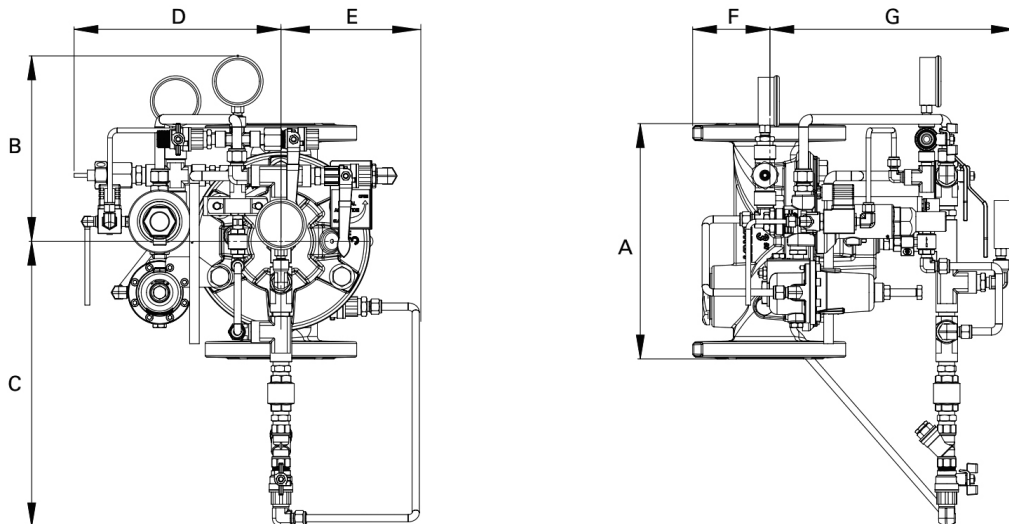

Model SD-DVH-PT680 DE\EL\HRV\PR

SHIELD

Deluge Pressure Reducing Valves

Typical Installation

The typical installation of the SD-DVH-PT680 DE\EL\HRV\PR is as shown:

- 1 Electrically or Hydraulically Actuated, Anti-Columning, Pressure Reducing Deluge Valve
- 2 Wet Pilot Line
- 3 Fire Alarm Control Panel
- 4 Heat/Smoke/Other Detectors
- 5 CXPR Pressure Reducing Pilot

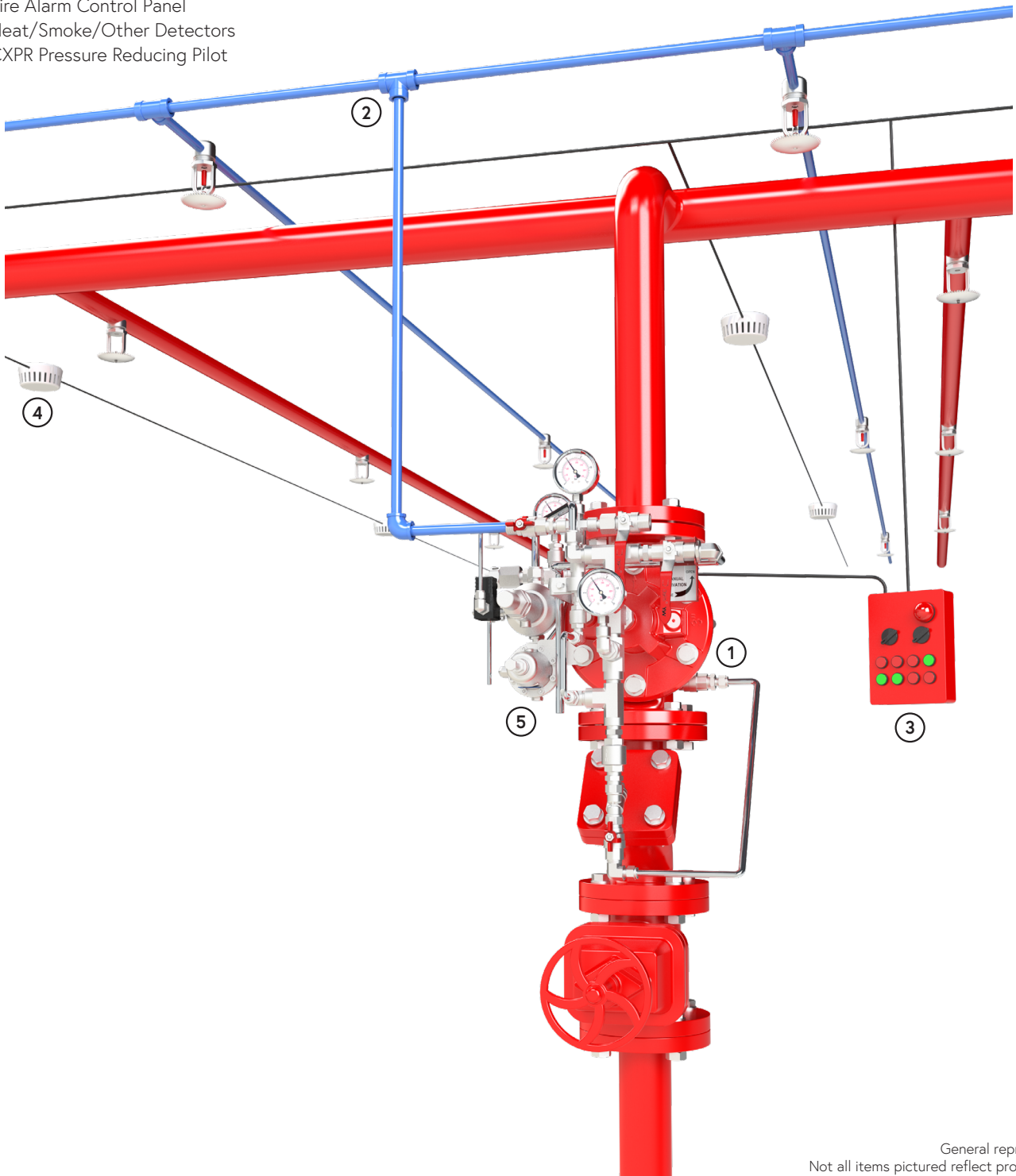

General representation.
Not all items pictured reflect products sold.

Model SD-DVH-PT680 DE\EL\HRV\PR

SHIELD

Deluge Pressure Reducing Valves

Technical Data

Temperature (Elastomers)	
Media	up to 80°C = 176°F
Elastomers	suitable for extreme climates (available upon request)
Sizes	
UL Listed Model SD-DVH-PT680	2" - 10"
Straight Flow	2" - 24"
Pressure Rating (ANSI at 100°F)	
250psi for Class 150#	
375psi for Class 300#	
End Connections	
Flanged	ISO-PN16 & ISO-PN25
	ANSI B16.42 & B16.5 Class 150# & 300#
	Additional options available upon request
Grooved	Sizes: 2"-8"

Body & Cover Material	
Ductile Iron	Stainless Steel
Cast Steel	NAB
Trim Material	
Bronze/Brass - Copper	
Stainless Steel	
Monel	
Optional Components	
Position Indicator	
Alarm Test Trim	
Upstream Drain Valve	
Pressure Switch	
Limit/Proximity Switch	
Items to Specify	
Electrical features other than standard (24VDC, IP65/NEMA4)	
If explosion proof accessories are required such as solenoids, pressure switches, etc., please define classification	
Control trim material other than standard	
Required standards, certifications and approvals	

Engineering Specifications

The deluge valve shall be hydraulically operated, direct elastomeric diaphragm-seal, single chamber weir type. The valve shall consist of three major components: the body, the cover and the diaphragm assembly. The diaphragm assembly shall be the only moving part. The diaphragm forms a sealed control chamber in the upper portion of the valve, separating operating pressure from line pressure. Packing glands, stuffing boxes and dynamic o-ring seals are not permitted and there shall not be shafts, discs, bearings or pistons operating the valve. No hourglass shaped disc retainers shall be permitted, and no V-type, U-type or other slotted type disc guides shall be used. The valve shall contain a nylon reinforced rubber diaphragm, elastic & resilient through its entire surface without vulcanized radial seals

and/or reinforcements. The diaphragm assembly shall not be guided by any shafts or bearings and shall not be in close contact with other valve parts except for its sealing surface. The deluge valve shall be fully trimmed, hydrostatically and operationally tested at the factory. Maintenance, disassembly and reassembly of all the valve's components shall be made possible on-site and in-line, without the need to remove the valve from the line. Main valve body and bonnet standard material shall be ductile iron or cast steel. Main valve body and bonnet surfaces shall include a fire red epoxy coating. Other materials and coatings are available upon request.