

SHIELD Series 100

Basic Valves



General representation



Fire Protection

Series 100 Basic Valve (Models 44, SD-DVH-PT680, 77)

Description

The Series 100 control valves are automatic, hydraulically actuated, direct diaphragm sealing globe/weir type valves with a proven and reliable design. These valves are designed for use in fire protection applications including deluge, pre-action, pressure relief, monitors, hydrants and are suitable for water, foam and seawater systems. The valves consist of three major components: body, cover and diaphragm assembly.

Model 44: Up to 230psi working pressure, threaded.

Model SD-DVH-PT680: Up to 375psi working pressure, flanged & grooved with drain port.

Model 77: Up to 230psi working pressure, flanged & grooved.

Certification & Compliance

UL Listed under categories:

QXZQ (Models 44 & 77), VLFT (Model SD-DVH-PT680)



ABS Type Approval



Lloyd's Type Approval



CCCf - Model SD-DVH-PT680 DE\EL(CN)



GOST-R



Fire Tested to EN ISO 6182-5:2006 - Model SD-DVH-PT680(2"-6")



Manufacture & Conformity Assessment of Pressure Equipment & Assemblies Directive (97/23/EC / EN1074)

Consult the UL Listing Guide, or contact Aquestia USA for a complete list of approved applications & valve sizes.

Features & Benefits

- Listed & approved for use in fire protection systems by various global standards
- Quick opening; Non-slam closing operation
- Drip-tight shut off to ANSI FCI 70-2 VI seat leakage class
- Simple & reliable construction
- Low lifelong maintenance costs due to straightforward design
- Easy installation & inline maintenance
- High grade construction materials
- Exceptionally low pressure losses
- Optional remote or manual reset
- Optional manual, electric, hydraulic, pneumatic & combined control trims
- Optional explosion proof, SIL redundant solenoids & trim accessories
- Optional seawater & foam concentrate service

Operation

Figure showing Model SD-DVH-PT680. Same principle of operation is applicable for Models 44 & 77.

Standard Operation:

Standby Position (Valve Closed)

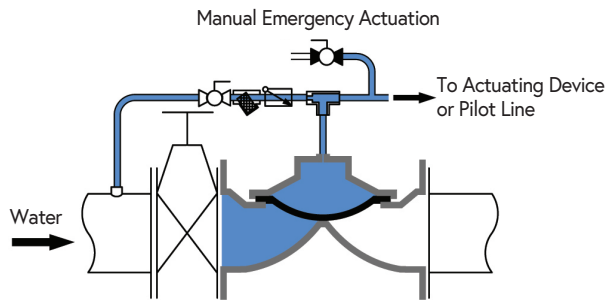

Fire Event (Valve Actuated Automatically or Manually)

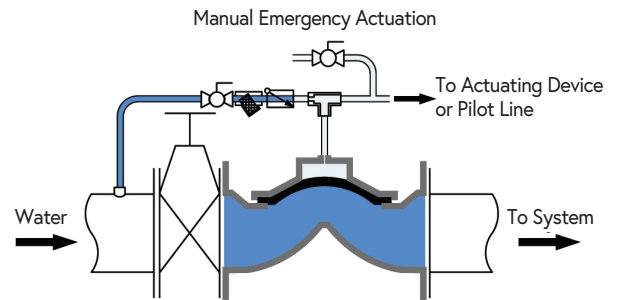

Manual Reset Operation:

Standby Position (Valve Closed)

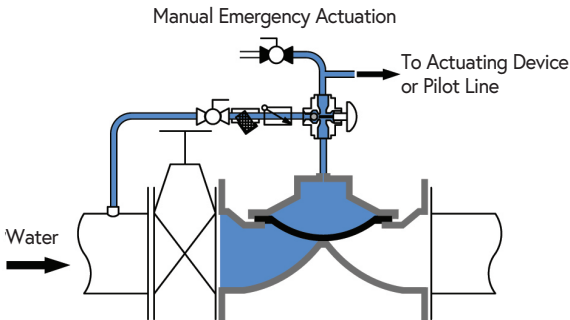

Fire Event (Valve Actuated Automatically or Manually)

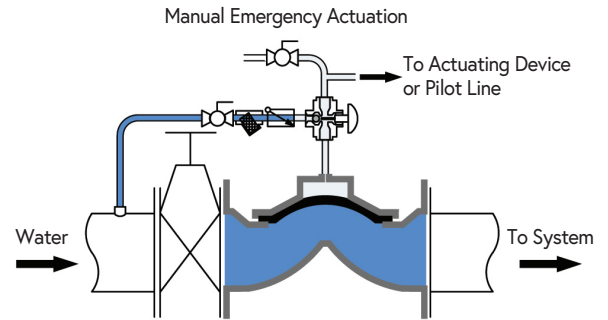

Reset to Close

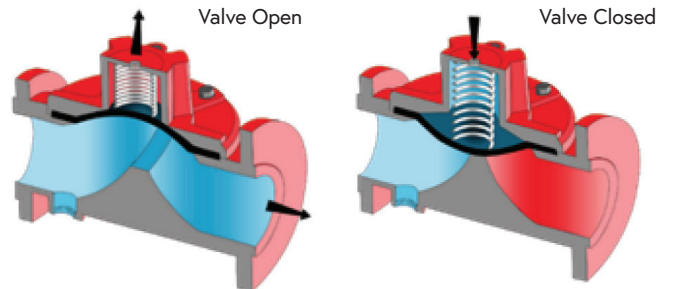
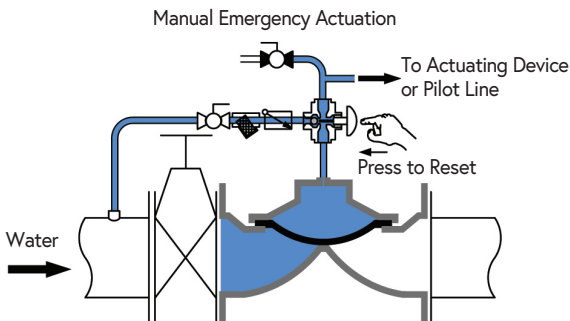

Resetting, maintenance, and periodic testing instructions must be followed as described in detail in the applicable IOM (Installation, Operation & Maintenance) Manual.

Components

ID	Part
1	Valve Body
2	Bonnet
3	Diaphragm
4	Spring*
5	Seat Disc*
6	Bolts
7	Washer
8	Nut
9	Suspension Hook

*Spring & Seat Disc Optional for Model SD-DVH-PT680

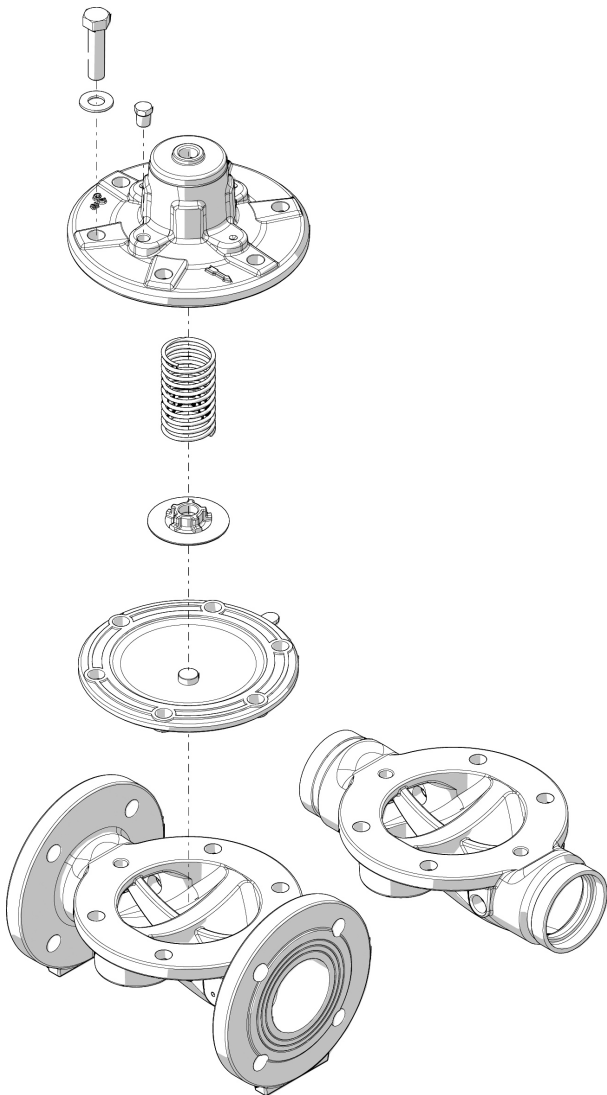
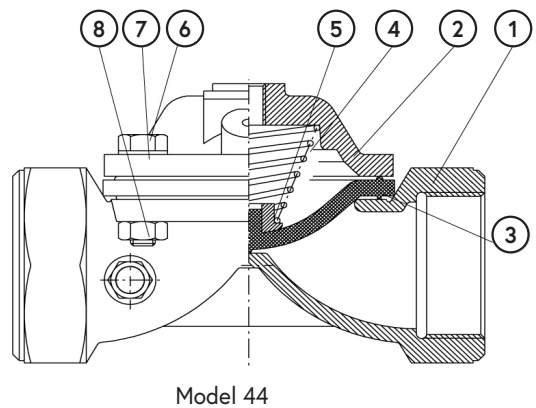
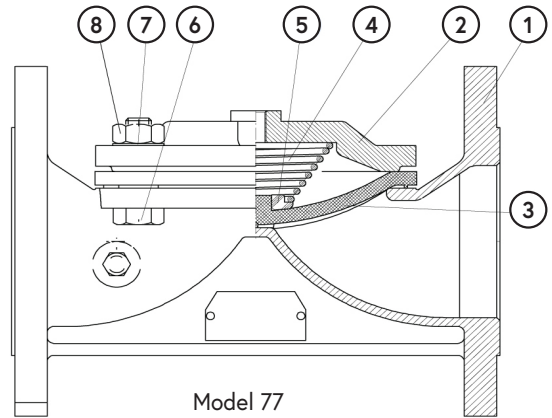
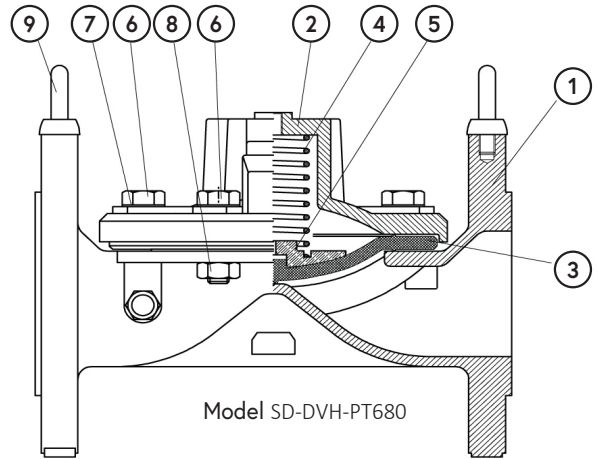

General Arrangement & Dimensions

SD-DVH-PT680 (Flanged)	2" (50)		2 1/2" (65)		3" (80)		4" (100)		6" (150)		8" (200)		10" (250)		12" (300)	
DIM	inch	mm	inch	mm	inch	mm	inch	mm	inch	mm	inch	mm	inch	mm	inch	mm
L	9 5/8	243	9 3/16	233	12 3/16	310	14	356	17 1/8	436	20 13/16	530	25	636	NA	
H	6 5/8	169	7 5/16	185	9 5/16	237	10 5/16	263	14 13/16	378	18 7/8	481	21 1/2	546		
R	3 5/16	85	3 11/16	92 1/2	4 1/8	105	4 11/16	120	5 7/8	150	7	180	8 3/8	215		
W*	6 7/8	175	7 5/16	185	7 13/16	200	10 3/16	260	12 5/8	320	15 11/16	400	19 3/8	495		
Approx. Weight	lbs	kg	lbs	kg	lbs	kg	lbs	kg	lbs	kg	lbs	kg	lbs	kg	lbs	kg
	22	10	32	14.5	66.1	30	83.8	38	165.3	75	271	123	419	190	NA	
SD-DVH-PT680 (Grooved)	2" (50)		2.5" (65)		3" (80)		4" (100)		6" (150)		8" (200)		10" (250)		12" (300)	
L	9 5/8	243	10	253	13 3/16	336	15	380	17 5/16	440	21 7/8	556	NA			
H	5 5/8	143	5 5/8	143	8 11/16	220	9	229	13 5/16	337	17	433				
R	2 3/16	55	2 3/16	55	3	77	3 3/8	86 1/2	4 1/2	114	5 1/2	139				
W*	6 13/16	172	6 13/16	172	9 5/16	236	10 5/16	261	12 13/16	326	15 11/16	400				
Approx. Weight	lbs	kg	lbs	kg	lbs	kg	lbs	kg	lbs	kg	lbs	kg	lbs	kg	lbs	kg
	13.7	6.2	14	6.4	32	14.5	46.3	21	85	38.5	145.5	66	NA			
77 (Flanged)	2" (50)		2.5" (65)		3" (80)		4" (100)		6" (150)		8" (200)		10" (250)		12" (300)	
L	7 13/16	200	8 3/8	214	11 3/16	285	12	305	15 5/16	390	18 1/8	460	21	535	22 13/16	580
H	6 1/2	166	7 5/16	185	7 13/16	200	9	230	12 5/16	314	15 11/16	400	17 1/2	445	19 3/8	495
R	3 5/16	85	3 5/8	92 1/2	4 1/8	105	4 5/16	110	5 11/16	145	6 5/8	170	8	205	9 3/8	240
W*	6 1/2	166	7 5/16	185	7 13/16	200	9	230	11 13/16	300	14 3/8	365	17 5/16	440	19 5/16	490
Approx. Weight	lbs	kg	lbs	kg	lbs	kg	lbs	kg	lbs	kg	lbs	kg	lbs	kg	lbs	kg
	17	7.7	22.7	10.3	40.1	18.2	53	24	108	49	190	86	276	125	368	167
44 (Threaded)	2" (50)		2.5" (65)		3" (80)											
TL	7 3/8	188	8 5/8	219	12 3/8	316										
TH	4 1/2	115	4 11/16	118	5 5/16	135										
TR	1 5/8	42	1 13/16	46	2	53										
W*	4 3/8	112	4 3/8	112	7 13/16	200										
Approx. Weight	lbs	kg	lbs	kg	lbs	kg										
	7	3.2	7.9	3.6	24	11										

Approximate dimensions. Contact for information on additional valve sizes & models.

*Valve Width

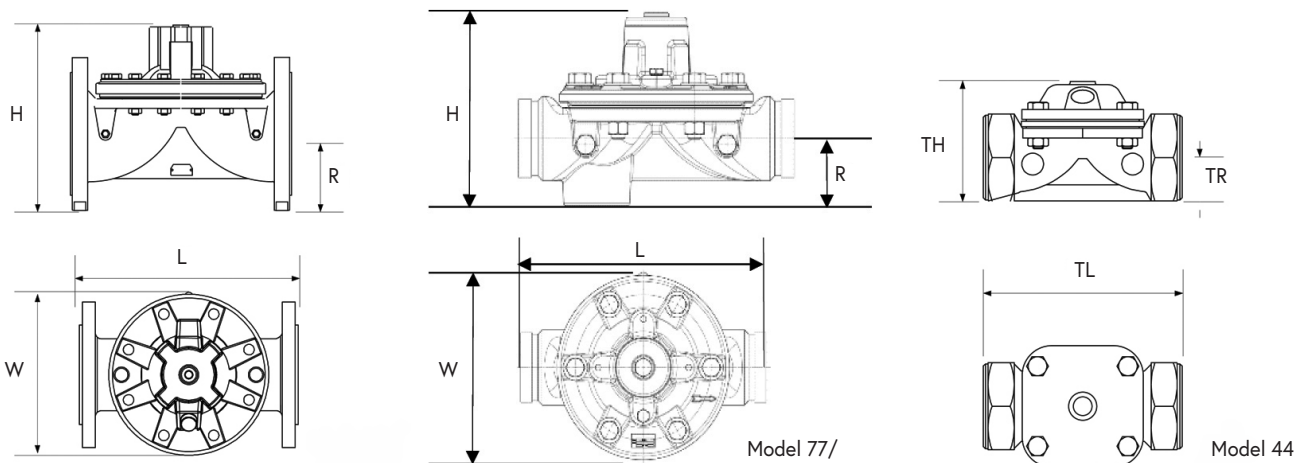

* General representation of valve

SHIELD Series 100

Basic Valves

Head Loss & Hydraulic Characteristics

Model SD-DVH-PT680 Head Loss

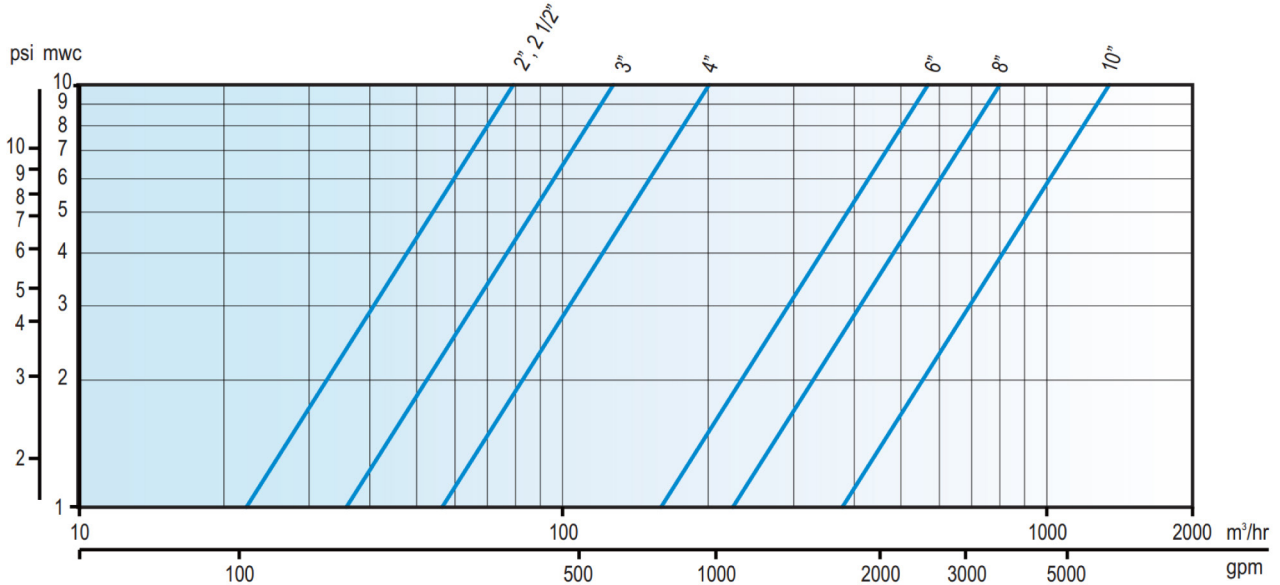

Model SD-DVH-PT680 Hydraulic Characteristics (UL Listed diameters shown in chart)

Valve Size		2" (50)	2 1/2" (65)	3" (80)	4" (100)	6" (150)	8" (200)	10" (250)
Kv	m³/hr @ 1 bar	78	78	120	200	550	800	1300
Cv	gpm @ 1 psi	91	91	140	234	643	935	1519
K Factor	NA	1 7/10	1 7/10	3 7/10	4 1/5	2 4/5	4 1/5	3 9/10
Equivalent Pipe Length @ C _{HW} = 120	Meters	3.7	13.3	16.4	18.9	20.9	42.5	51.2
	Feet	12	44	54	62	69	139	168
Control Chamber Displacement Volume	Liters	0.18	0.18	0.3	0.5	2	4.8	6.2
	Gallons	0.5	0.5	0.8	1.3	0.53	1.27	1.64

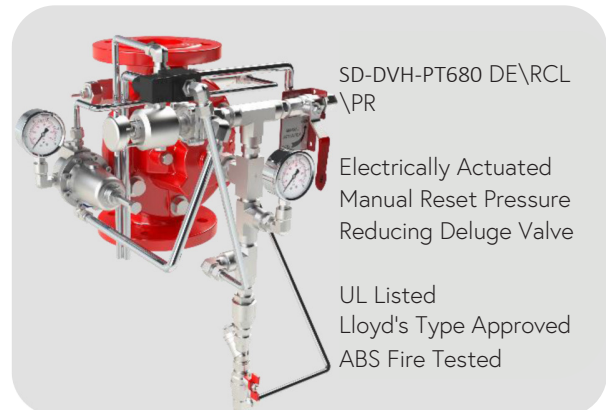

Head Loss & Hydraulic Characteristics

Model 44 & 77 Head Loss

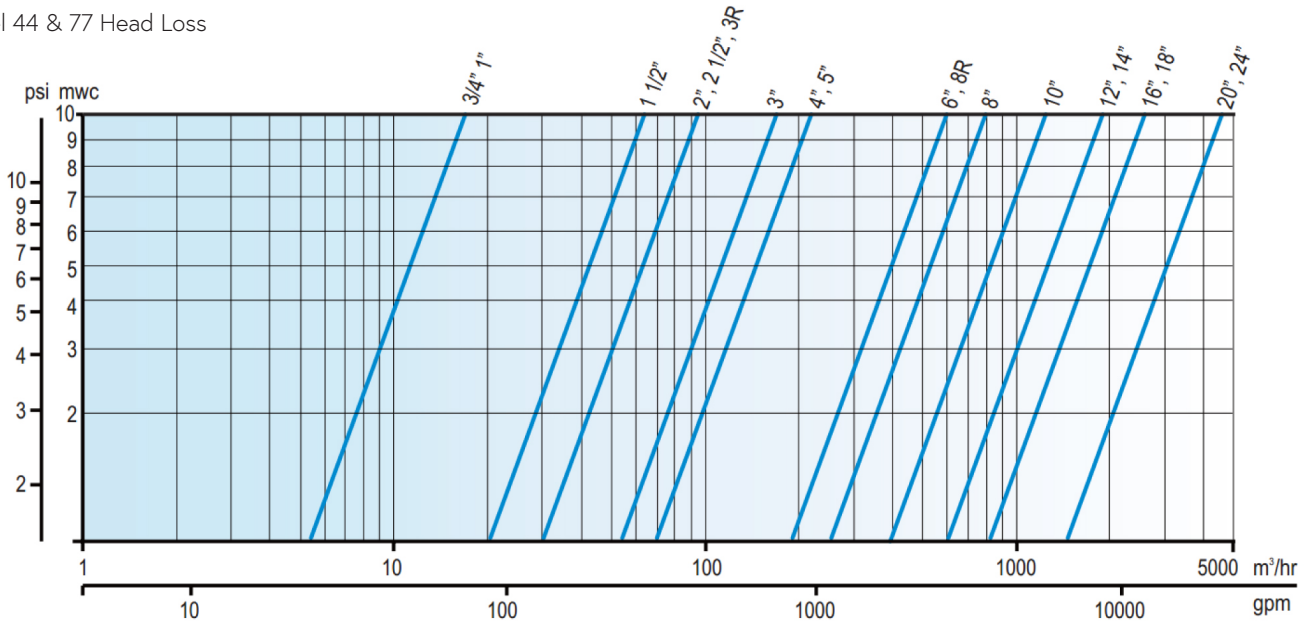

Model 44 & 77 Hydraulic Characteristics (UL Listed diameters shown in chart)

Valve Size		1" (25)	1 1/2" (40)	2" (50)	2 1/2" (65)	3" (80)	4" (100)	6" (150)	8" (200)	10" (250)	12" (300)
Kv	m ³ /hr @ 1 bar	17	64	95	95	170	220	600	800	1250	1900
Cv	gpm @ 1 psi	20	75	110	110	200	260	700	930	1460	2220
K Factor	NA	2 1/5	1	1 1/10	3 1/5	2 3/10	3 3/10	2 1/5	4	4	3 3/5
Equivalent Pipe Length @ C _{HW} = 120	Meters	2	2	3	9	9	16	18	42	55	62
	Feet	7	6	8	30	28	52	58	139	181	202
Control Chamber Displacement Volume	Liters	.03	.07	.16	.16	.6	.6	1.8	4.7	6.5	9.4
	Gallons	.01	.02	.04	.04	.16	.16	.48	1.24	1.72	2.48

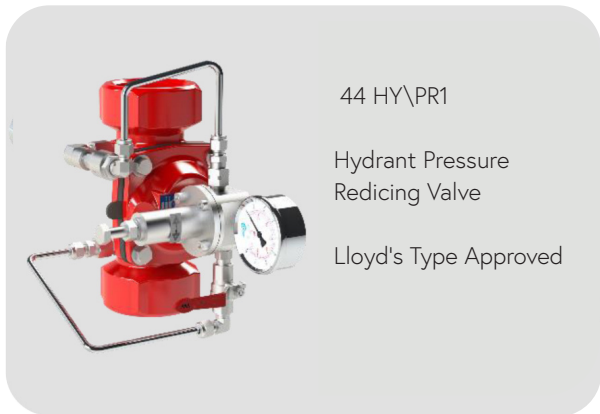

Pressure Rating

Recommended nominal system pressure to flange class for typical materials as:

- Ductile Iron ASTM A536
- Stainless Steel ASTM CF8M
- Cast Steel ASTM A216 & ASTM A352 LCB
- NAB ASTM B148 C-95800
- 250psi nominal system pressure for flanges ANSI B16.42 & ANSI B16.50 Class 150# accordingly
- 375psi maximal system pressure for flanges ANSI B16.42 & ANSI B16.50 Class 300# accordingly

Material		End Connections	Valve Sizes	Standard	Max. Recommended Working Pressure
Ductile Iron ASTM A536	Flanged	150# RF (or FF)	2"-12"	ASME / ANSI B16.42	250psi / 17.2 bar
		300# RF (or FF)	2"-12"	ASME / ANSI B16.42	375psi / 25.8 bar
		PN16	2"-12"	ISO 7005-2	230psi / 16 bar
		PN25	2"-12"	ISO 7005-2	360psi / 25 bar
	Grooved	PN16	2"-8"	ASME / ANSI AWWA 606	230psi / 16 bar
		PN25	2"-8"	ASME / ANSI AWWA 606	360psi / 25 bar
	Threaded	PN16	2"-3"	BSP /NPT	230psi / 16 bar
		PN25	2"-3"	BSP / NPT	360psi / 25 bar
Cast Steel WCB ASTM A216 LCB ASTM A352 Stainless Steel ASTM CF8M NAB ASTM B148 C-95800	Flanged	150# RF (or FF)	2"-10"	ASME / ANSI B16.50	250psi / 17.2 bar
		300# RF (or FF)	2"-10"	ASME / ANSI B16.50	375psi / 25.8 bar
		PN16	2"-10"	ISO 7005-2	230psi / 16 bar
		PN25	2"-10"	ISO 7005-2	360psi / 25 bar

For exact pressure & temperature ratings see relevant ASME/ANSI B16 Standards for Pipes and Fittings. Contact for information on additional materials and standards.

Technical Data

Temperature (Elastomers)			
Water	up to 85°C / 185°F max		
Sizes			
Straight Flow	1/4" - 24" / 20-600mm		
UL Listed	2"-10" / 50-250mm		
Lloyd's Type Approved	1" - 24" / 25-600mm		
End Connections			
Flanged (Models SD-DVH-PT680 & 77) 1"-24"	ISO-PN16 & ISO-PN25		
	ASME/ANSI B16.42 & B16.5 Class 150# & 300#		
	Additional options available upon request		
Grooved (Models SD-DVH-PT680 & 77) 2" - 8"	ASME/ANSI AWWA 606		
Threaded (SD-DVH-PT680 Model 44) 1/4"-3"	BSP/NPT		
Elastomers			
Neoprene	NR	NBR	EPDM
Coating Material			
High Built, Fusion Bonded Epoxy			
Optional Coating Material			
UV Protection	Polyester		
Other coatings conforming to ISO-12944C4, C5 & C5M			
Internal Trim Material			
Stainless Steel			

Body & Cover Material	
Ductile Iron ASTM A536	Stainless Steel ASTM CF8M
Cast Steel ASTM A216 & A352 LCB	NAB ASTM B148 C-958000
Control Trim & Accessories	
Brass	Stainless Steel
Bronze	Monel
NAB	Super Duplex
Optional Components	
Pressure Switch	Alarm Test Trim
Pressure Reducing Feature	Position Indicator
Drain Valve	Explosion Proof
Open/Close Speed Control	Block & Bleed Valves for Pressure Sensing Control
PPCS (Pneumatic Pressure Control System for Pneumatically Actuated Models)	Limit Proximity Switch Assembly
Items to Specify	
Electrical features other than standard (24VDC, IP65/NEMA4)	
If explosion proof accessories are required such as solenoids, pressure switches, etc., please define classification	
Control trim material other than standard	
Required standards, certifications and approvals	