

# MINIATURE RELIEF VALVE

SD-CRVT SERIES

## SAFETY VALVE APPLICATION

- The safety valves are used in mold temperature controller, air compressor, water system, oil pipe, gas system and so on.

## OPERATING PRINCIPLE

- After installing in the piping system, the safety valve will work automatically when the pressure of medium in the system is reaching to the set value. It releases pressure to protect the system.

## OPERATING TEMPERATURE

- FKM Sealing: -20~ 180 °C, RPTFE Sealing: -60 ~ 220 °C  
PTFE Sealing: -60~ 170 °C, EPDM Sealing: -40 ~ 110 °C

## TECHNICAL PARAMETERS

Model	Operating Pressure	Setting Pressure
SD-CRVT	5 - 15 Bar	15 Bar
SD-CRVT-2	15 - 24 Bar	22 Bar



## GENERAL MATERIAL

Part	Material	ASTM Specification
1	Cap	CW617N
2	Adjust Screw	CW617N
3	Nut	CW617N
4	Spindle	CW617N
5	Spring	SS304
6	Valve Body	BRONZE
7	Spring Seat	CW617N
8	Disc	CW617N
9	Gasket	PTFE/FKM/EPDM/RPTFE
10	Buffer	CW617N
11	Gasket Ring	PTFE
12	Valve Seat	CW617N

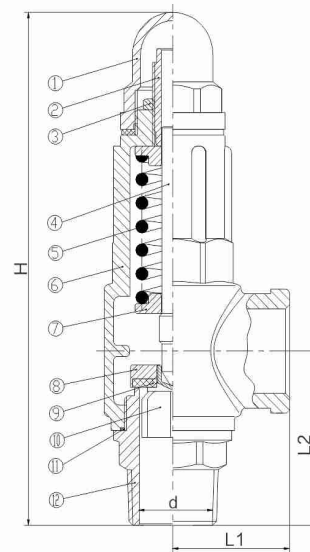

## DIMENSION

Inlet	D	Outlet	Lift	L1	L2	H
3/8"	10	3/8"	0.4	27	38	117
1/2"	13	1/2"	0.5	31	48	135
3/4"	19	3/4"	0.7	35	55	144
1"	25	1"	0.9	39.5	65	175
1 1/4"	32	1 1/4"	1.2	50.5	75	197
1 1/2"	37	1 1/2"	1.4	59	86	223
2"	47	2"	1.8	67	100	257

### SHIELD FIRE, SAFETY & SECURITY LTD

Unit 3, Endeavour Drive, Basildon-Essex, SS14 3WF, United Kingdom  
Tel: +44 1708 377731 Fax: +44 1708 347637, E-mail: info@shieldglobal.com  
www.shieldglobal.com