

PRESSURE SWITCH

Model: SD-PS Series



FEATURES

- Sensitivity adjustment wheel, no special tools required
- Reinforced diaphragm resists pressure spikes
- Two conduit entrances
- Both one- and two-switch models available

SPECIFICATIONS

- Maximum Operating Pressure : 300 psi
- Maximum Adjustment Pressure Range :
SD-PS1001/SD-PS1002: 4-20 PSI
SD-PS4001/SD-PS4002: 10-100 PSI
SD-PS12001/SD-PS12002: 10-200 PSI

FACTORY SETTING :

- SD-PS1001 / SD-PS1002 : 4-8 PSI
- SD-PS4001 : Operates at decreasing pressure at 30 PSI
- SD-PS4002 : Operates at increasing pressure at 50 PSI and decreasing pressure at 30 PSI
- SD-PS12001 : Operates at decreasing pressure at 110 PSI
- SD-PS12002 : Operates at increasing pressure at 130 PSI and decreasing pressure at 30 PSI

APPROXIMATE DIFFERENTIAL :

- SD-PS1001/SD-PS1002: 3 PSI throughout range
- SD-PS4001/SD-PS4002 : 3 PSI @ 10 PSI & 6 PSI @ 100PSI
- SD-PS12001/SD-PS12002 : 3 PSI @ 10 PSI & 9 PSI @ 200 PSI
- **Pressure Connection:** ½" NPT male glass reinforced nylon
- **Contact Rating:** 10 A @125/250 VAC 2.5 A @ 30VDC
- **Temperature Range:** -40°F to 140°F (-40°C to 60°C)

SERVICE USE

- Automatic Sprinkler: NFPA 13
- One or Two Family Dwelling: NFPA 13D
- Residential Occupancies up to 4 Stories: NFPA 13R
- National Fire Alarm Code: NFPA 72



DESCRIPTION

The SD-PS Series Pressure Switches shall be installed on the sprinkler system with connection as shown on the drawings and/or as specified herein. Pressure switches shall be of the bellows-activated type. Switches shall have a maximum service pressure rating of 300 psi and shall be factory adjusted to operate at a pressure of 4 - 8 psi. There shall be one (1) or two (2) SPDT contacts rated at 10.0 Amp @ 125/250 VAC and 2.5 Amp @ 30 VDC. The contractor shall furnish and install, where indicated on the plans, pressure switches according to appropriate NFPA standards. Switches shall be provided with a ½" NPT male pressure connection to be connected to the alarm check valve of a "wet" sprinkler system, into the intermediate chamber of a "dry" system, or to a pre-action or deluge valve. They shall be activated by any flow of water equal to or in excess of the discharge from one sprinkler head. Switches shall provide 1 knockout type and 1 open hole for ½" conduit fitting attachment and a ground screw provision for electrical grounding. The switch enclosure shall be weatherproof. The cover shall incorporate tamper resistant screws. The unit shall be listed by Underwriters Laboratories, Inc. and approved by Factory Mutual.

INSTALLATION

The Pressure Actuated Switches are designed for the detection of a waterflow condition in automatic fire sprinkler systems of particular designs such as wet pipe systems with alarm check valves, dry pipe, preaction, or deluge valves.

1. Apply Teflon tape to the threaded male connection on the device. *(Do not use pipe dope)*
2. Device should be mounted in the upright position (threaded connection down).
3. Tighten the device using a wrench on the flats on the device.

WIRING INSTRUCTIONS

1. Remove the tamper resistant screw with the special key provided.
2. Carefully place a screwdriver on the edge of the knockout and sharply apply a force sufficient to dislodge the knockout plug.
3. Run wires through an approved conduit connector and affix the connector to the device.
4. Connect the wires to the appropriate terminal connections for the service intended.

TESTING

The operation of the pressure alarm switch should be tested upon completion of installation and periodically thereafter in accordance with the applicable NFPA codes and standards and/or the authority having jurisdiction (manufacturer recommends quarterly or more frequently).

WET SYSTEM

- **Method 1:** When using pressure switch and control unit with retard - connect pressure switch into alarm port piping on the input side of retard chamber and electrically connect pressure switch to control unit that provides a retard to compensate for surges. Insure that no unsupervised shut-off valves are present between the alarm check valve and pressure switch.
- **Method 2:** When using the pressure switch for local bell application or with a control that does not provide a retard feature - the pressure switch must be installed on the alarm outlet side of the retard chamber of the sprinkler system.
- **Testing:** Accomplished by opening the inspector's end offline test valve. Allow time to compensate for system or control retard. Note: Method 2 is not applicable for remote station service use, if there is an unsupervised shut-off valve between the alarm check valve and the pressure switch.

WET SYSTEM WITH EXCESS PRESSURE

Connect pressure switch into alarm port piping extending from alarm check valve. Retard provisions are not required. Insure that no unsupervised shut-off valves are present between the alarm check valve and the pressure switch.

- **Testing:** Accomplished by opening the water by-pass test valve or the inspector's end-of-line test valve. When using end-of-line test, allow time for excess pressure to bleed off.

DRY SYSTEM

Connect pressure switch into alarm port piping that extends from the intermediate chamber of the alarm check valve. Install on the outlet side of the in-line check valve of the alarm port piping. Insure that no unsupervised shut-off valves are present between the alarm check valve and the pressure switch.

- **Testing:** Accomplished by opening the water by-pass test valve.
- **Note:** The above tests may also activate any other circuit closer or water motor gongs that are present on the system.

DIMENSIONS

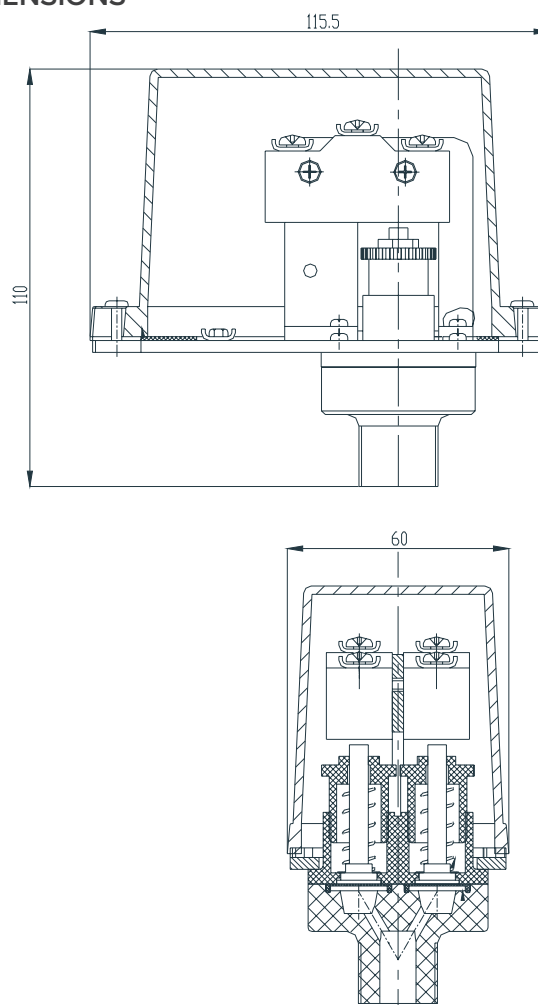

TYPICAL CONNECTIONS

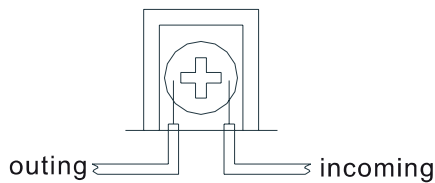
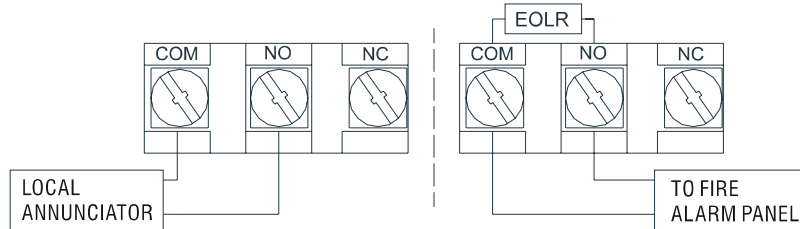

An uninsulated section of a single conductor should not be looped around the terminal and serve as two separate connections. The wire must be severed, thereby providing supervision of the connection in the event that the wire becomes dislodged from under the terminal.

TYPICAL SPRINKLER APPLICATIONS

