

Shield - Deluge Valve Part list

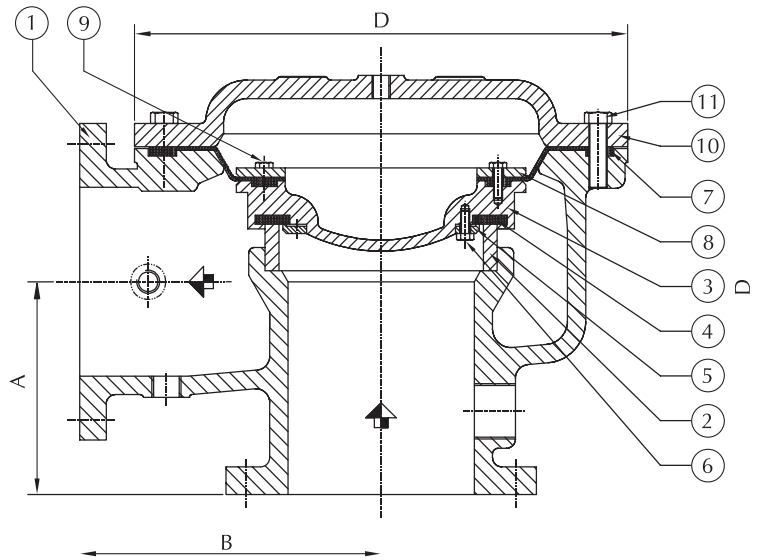

DIMENSION in millimeter (Approximate)

VALVE NOMINAL SIZE	'A'	'B'	'C'	'D'
200 NB	230	330	455	540
150 NB	200	300	382	464
100 NB	165	240	304	370
80 NB	135	210	272	316
50 NB	135	210	272	316

PART LIST

ITEM	PART NO.					DESCRIPTION	QTY.					MATERIAL SPECIFICATION
	200 NB	150 NB	100 NB	80 NB	50 NB		200 NB	150 NB	100 NB	80 NB	50 NB	
1	2181	2101	2121	2141	2161	HOUSING	1	1	1	1	1	CAST IRON IS:210 GR.FG 260
2	2187	2107	2127	2147	2147	SEAT	1	1	1	1	1	BRONZE IS:318 LTB-II
3	2185	2105	2125	2145	2145	CLAPPER	1	1	1	1	1	BRONZE IS:318 LTB-II
4	2189	2109	2129	2149	2149	SEAT RUBBER	1	1	1	1	1	NEOPRENE
5	2190	2110	2130	2150	2150	RUBBER CLAMP	1	1	1	1	1	BRONZE IS:318 LTB-II
6	-	-	-	-	-	BOLT	6	4	4	3	3	STAINLESS STEEL 304
7	2188	2108	2128	2148	2148	DIAPHRAGM	1	1	1	1	1	NEOPRENE
8	2186	2106	2126	2146	2146	CLAMP RING	1	1	1	1	1	BRONZE IS:318 LTB-II
9	-	-	-	-	-	BOLT	12	12	8	8	8	STAINLESS STEEL 304
10	2184	2104	2124	2144	2144	COVER	1	1	1	1	1	CAST IRON IS:210 GR.FG 260
11	-	-	-	-	-	BOLT	16	16	12	12	12	STEEL IS:1363

Shield/2005 Shield reserves the right to change the contents without notice.

